

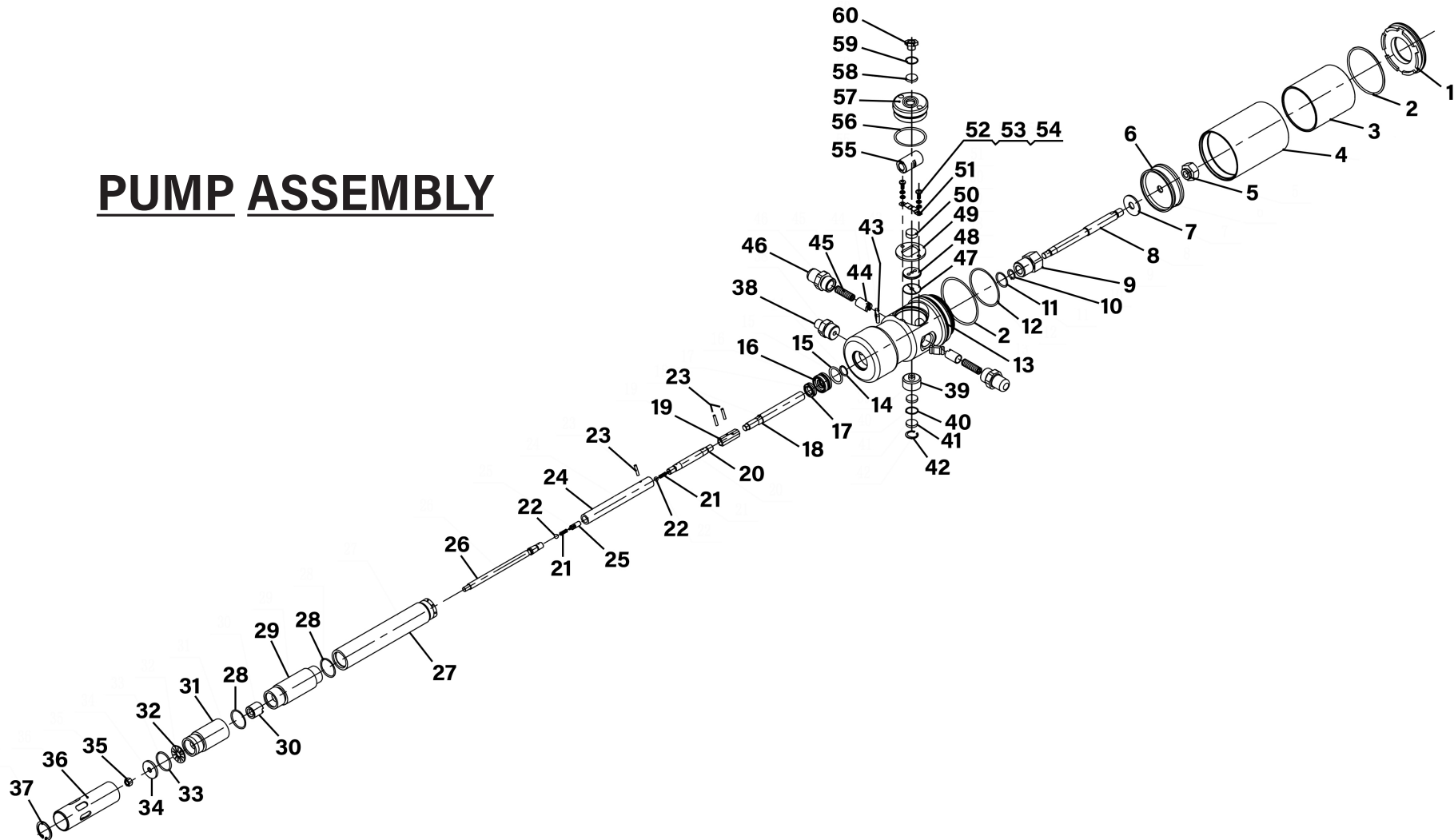

Parts Information:  
Grease Pump Air Operated 12.5kg  
Model No: AK452X.V4

# PUMP ASSEMBLY



**NOTE:** It is our policy to continually improve products and as such we reserve the right to alter data, specifications and component parts without prior notice.

There may be alternative versions of this product, please contact us should you require this information.

**IMPORTANT:** No liability is accepted for incorrect use of product. Spare parts must be fitted by a competent person

**WARRANTY:** Guarantee is 12 months from purchase date, proof of which will be required for any claim.

Sealey Group, Kempson Way, Suffolk Business Park, Bury St Edmunds, Suffolk. IP32 7AR



01284 757500



sales@sealey.co.uk



www.sealey.co.uk



Parts Information:  
**Grease Pump Air Operated 12.5kg**  
**Model No: AK452X.V4**

Item	Part No.	Description	Qty
1	AK453X.V3-P06	Air Motor Cover	1
2	AK453X.V3-P02	O-ring, (Ex: 73.19 In: 67.95 Cs: 2.62)	2
3	AK453X.V3-P05	Air Motor Shell Inside	1
4	AK453X.V3-P04	Air Motor Shell Outside	1
5	AK453X.V3-P07	Nut	1
6	AK453X.V3-P08	Rubber Piston Block	1
7	AK453X.V3-P09	Gasket	1
8	AK453X.V3-P10	Piston Shaft	1
9	AK453X.V3-P11	Piston Rod Guide Sleeve	1
10	SA695.13	O-ring, (Ex: 16.01 In: 10.77 Cs: 2.62)	1
11	SA686.36	O-ring, (Ex: 22.33 In: 18.77 Cs: 1.78)	1
12	AK453X.V3-P03	O-ring, (Ex: 66.84 In: 61.60 Cs: 2.62)	1
13	AK453X.V3-P01	Cylinder Block	1
14	AK453X.V3-P19	O-ring, (Ex: 15.63 In: 11.77 Cs: 1.93)	1
15	MT700.V2-R10	O-ring, (Ex: 25.53 In: 20.29 Cs: 2.62)	1
16	AK453X.V3-P17	Sealing Socket	1
17	AK453X.V3-P16	Oil Seal Green 12mm ID	1
18	AK453X.V3-P15	Centre Shaft	1
19	AK453X.V3-P21	Connect Shell	1
20	AK453X.V3-P23	Connect Shaft 'New Type' (10X428)	1
21	AK453X.V3-P25	Compression Spring Dia 4mm	2
22	SB-6.0	Steel Ball 6.0mm	2
23	SA2/05	Spring Pin M3 X 14	3
24	AK453X.V3-P27	Piston	1
25	AK453X.V3-P28	Spring Seat	1
26	AK453X.V3-P29	Shaft	1
27	AK453X.V3-P24	Outer Sleeve	1
28	SA0615KIT.08	O-ring, (Ex: 23.91 In: 20.35 Cs: 1.78)	2
29	AK453X.V3-P30	Plug Sleeve	1
30	AK453X.V3-P31	Valve Set	1
31	AK453X.V3-P32	Valve Seat	1

Item	Part No.	Description	Qty
32	AK453X.V3-P33	Filter Plate	1
33	AK453X.V3-P38	O-ring, (Ex: 27.08 In: 23.52 Cs: 1.78)	1
34	AK453X.V3-P35	Extract Plate	1
35	NLN6.S	Nyloc Nut M6 Zinc	1
36	AK453X.V3-P37	Tube	1
37	AK453X.V3-P34	Internal Circlip 32.0mm OD.	1
38	AK453X.V3-P44	Joint	1
39	AK453X.V3-P39N	Muffler Seat	1
40	AK453X.V3-P40N	O-Ring 27.3 x 2.65mm	1
41	AK453X.V3-P41N	Silencer	1
42	AK453X.V3-P42N	Internal Circlip 32mm	1
43	AK453X.V3-P40	Toggle Block	2
44	AK453X.V3-P43	Inner Spring Fixed Seat	2
45	AK453X.V3-P42	Compression Spring Dia 9.8mm	2
46	AK453X.V3-P41	Outer Spring Fixed Seat	2
47	AK453X.V3-P52	Gasket	1
48	AK453X.V3-P51	Gasket	1
49	AK453X.V3-P50	Limit Plate	1
50	AK453X.V3-P47	Silencer	1
51	AK453X.V3-P56	Plate	1
52	MSP410.S	Machine Screw Pan Head Phillips M4 X 10mm	2
53	SWM4.S	Spring Washer M4 Zinc	2
54	FWM4.S	Flat Washer M4	2
55	AK453X.V3-P14	Sliding Sleeve	1
56	AK453X.V3-P49	O-Ring, (Ex: 46.18 In: 40.94 Cs: 2.62)	1
57	AK453X.V3-P57N	Seal Cover	1
58	AK453X.V3-P58N	Silencing Plug	1
59	AK453X.V3-P59N	O-Ring 18.5 x 3mm	1
60	AK453X.V3-P60N	Air Inlet Connection Joint	1

**NOTE:** It is our policy to continually improve products and as such we reserve the right to alter data, specifications and component parts without prior notice. There may be alternative versions of this product, please contact us should you require this information.

**IMPORTANT:** No liability is accepted for incorrect use of product. Spare parts must be fitted by a competent person

**WARRANTY:** Guarantee is 12 months from purchase date, proof of which will be required for any claim.

Sealey Group, Kempson Way, Suffolk Business Park, Bury St Edmunds, Suffolk. IP32 7AR



01284 757500



sales@sealey.co.uk



www.sealey.co.uk

## TROLLEY ASSEMBLY

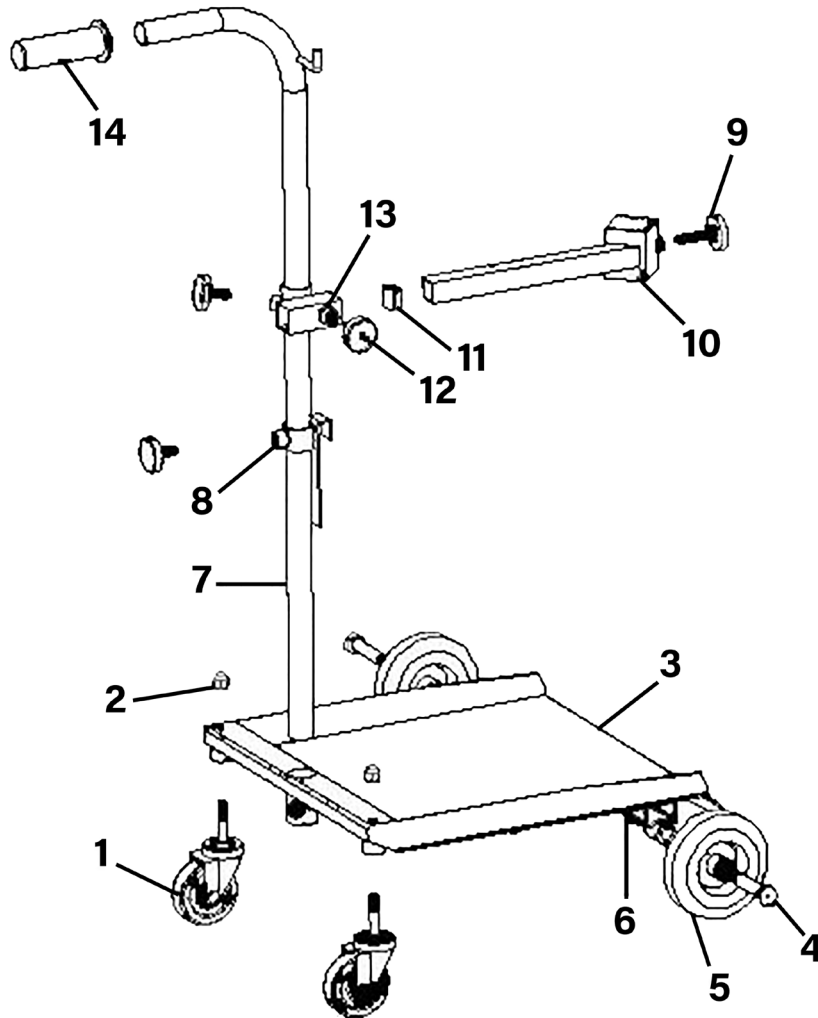

Item	Part No.	Description
1	AK453X.V3-T01	Wheel,Swivel Castor, Single Bolt (D:75 W:25 B:8 H:149)
2	SN10.SD	Steel Nut M10 Domed
3	AK453X.V3-T03	Trolley Base
4	HHB1490.S	Hex Head Bolt M14 x 90mm
5	AK453X.V3-T05	Wheel,Fixed (D:125 W:36 B:14)
6	SN14.S	Steel Nut M14
7	AK453X.V3-T07	Handle
8	AK453X.V3-T08	Fixing Nut
9	AK453X.V3-T09	Knob, OD: 40mm, M10x45mm Threaded Male Fitting
10	AK453X.V3-T10	Holder, Grease Gun
11	AK453X.V3-T11	End Plug

Item	Part No.	Description
12	AK453X.V3-T12	Knob, OD: 39mm, M10x24mm Threaded Male Fitting
13	AK453X.V3-T13	Pump Support
14	AK453X.V3-T14	Handle Grip
--	<b>AK453X.V3-01</b>	<b>Grease Pump ***See Diagram***</b>
--	AK452X.V3-03	Drum Cover 280mm (Not Shown)
--	AK452X.V3-04	Follower Plate 265mm (Not Shown)
--	AK453X.V3-05	High Pressure Grease Hose 4m (Not Shown)
--	AK453X.V3-06	Grease Control Gun (Not Shown)
--	AK453X.V3-07	Filter/Regulator/Lubricator Assembly (Not Shown)
--	AK453X.V3-08	Z-Swivel Connector (Not Shown)
--	AK453X.V3-T	Trolley Assembly (Not Shown)

**NOTE:** It is our policy to continually improve products and as such we reserve the right to alter data, specifications and component parts without prior notice. There may be alternative versions of this product, please contact us should you require this information.

**IMPORTANT:** No liability is accepted for incorrect use of product. Spare parts must be fitted by a competent person

**WARRANTY:** Guarantee is 12 months from purchase date, proof of which will be required for any claim.